

DH-IPC-HDW1220S

2MP Full HD Network Small IR Eyeball Camera



Features

- 1/2.7" 2Megapixel progressive scan CMOS
- H.264&MJPEG dual-stream encoding
- 25/30fps@2M(1920×1080)
- DWDR, Day/Night(ICR), 3DNR, AWB, AGC, BLC
- Multiple network monitoring: Web viewer, CMS(DSS/PSS) & DMSS
- 3.6mm fixed lens (6mm optional)
- Max. IR LEDs Length 30m
- IP67, PoE

DH-IPC-HDW1220S

Technical Specifications

Model	DH-IPC-HDW1220S	
Camera		
Image Sensor	1/2.7" 2Megapixel progressive scan CMOS	
Effective Pixels	1920(H) × 1080(V)	
Scanning System	Progressive	
Electronic Shutter Speed	Auto/Manual, 1s~1/30000s	
Min. Illumination	0.025Lux/F2.1(Color), 0Lux/F2.1(IR on)	
S/N Ratio	More than 50dB	
Video Output	N/A	
Camera Features		
Max. IR LEDs Length	30m	
Day/Night	Auto(ICR)/Color/B/W	
Backlight Compensation	BLC / HLC / DWDR	
White Balance	Auto/Manual	
Gain Control	Auto/Manual	
Noise Reduction	3D	
Privacy Masking	Up to 4 areas	
Lens		
Focal Length	3.6mm(6mm optional)	
Max Aperture	F2.1(F2.0)	
Focus Control	Manual	
Angle of View	H: 93°(63°)	
Lens Type	Fixed lens	
Mount Type	Board-in Type	
Video		
Compression	H.264/ H.264H/ H.264B/ MJPEG	
Resolution	1080P(1920x1080)/720P(1280x720)/ D1(704x576/704x480) / CIF(352x288/352x240)	
Frame Rate	Main Stream	1080P(1 ~ 25/30fps)
	Sub Stream	D1(1 ~ 25/30fps)
Bit Rate	H.264: 4kbps~8192bps	
Corridor Mode	Support	
Audio		
Compression	N/A	
Interface	N/A	
Network		
Ethernet	RJ-45 (10/100Base-T)	
Wi-Fi	N/A	
Protocol	IPv4/IPv6, HTTP, HTTPS, TCP/IP, UDP, UPnP, ICMP, IGMP, RTSP, RTP, SMTP, NTP, DHCP, DNS, PPPOE, DDNS, FTP, IP Filter, QoS	
Compatibility	ONVIF, CGI	
Max. User Access	20 users	

DH-IPC-HDW1220S

Smart Phone	iPhone, iPad, Android, Windows Phone
Auxiliary Interface	
Memory Slot	N/A
RS485	N/A
Alarm	N/A
PIR Sensor Range	N/A
General	
Power Supply	DC12V, PoE (802.3af)
Power Consumption	<4.4W(IR on)
Working Environment	-30°C~+60°C, Less than 95% RH
Ingress Protection	IP67
Vandal Resistance	N/A
Dimensions	Φ108mm × 84mm
Weight	0.25Kg(with package 0.38Kg)

DH-IPC-HDW1220S

Dimensions (mm)

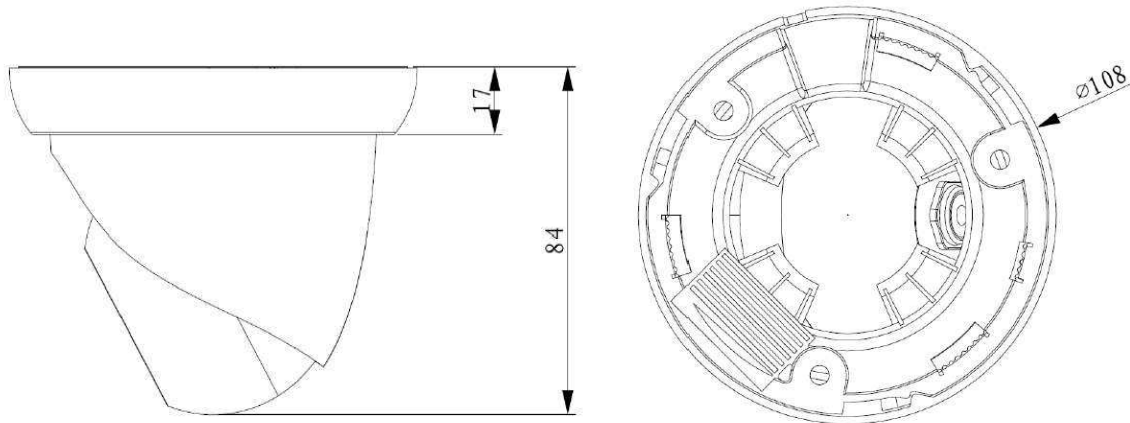

Accessories (optional)

		
PFA122	PFB200W	PFA152

Dahua Technology Co., Ltd.

1187BinAn Road, Binjiang District, Hangzhou, China

Tel: +86-571-87688883

Fax: +86-571-87688815

Email: overseas@dahuatech.com

www.dahuasecurity.com

*Design and specifications are subject to change without notice.

© 2015 Dahua Technology Co., Ltd.